

Service Manual

Finisher, Sorter, DeliveryTray
Additional Finisher Tray-C1

Canon

Application

This manual has been issued by Canon Inc. for qualified persons to learn technical theory, installation, maintenance, and repair of products. This manual covers all localities where the products are sold. For this reason, there may be information in this manual that does not apply to your locality.

Corrections

This manual may contain technical inaccuracies or typographical errors due to improvements or changes in products. When changes occur in applicable products or in the contents of this manual, Canon will release technical information as the need arises. In the event of major changes in the contents of this manual over a long or short period, Canon will issue a new edition of this manual.

The following paragraph does not apply to any countries where such provisions are inconsistent with local law.

Trademarks

The product names and company names used in this manual are the registered trademarks of the individual companies.

Copyright

This manual is copyrighted with all rights reserved. Under the copyright laws, this manual may not be copied, reproduced or translated into another language, in whole or in part, without the written consent of Canon Inc.

COPYRIGHT © 2001 CANON INC.









Printed in Japan

Caution

Use of this manual should be strictly supervised to avoid disclosure of confidential information.



Symbols Used

This documentation uses the following symbols to indicate special information:

Symbol	Description
	Indicates an item of a non-specific nature, possibly classified as Note, Caution, or Warning.
	Indicates an item requiring care to avoid electric shocks.
	Indicates an item requiring care to avoid combustion (fire).
	Indicates an item prohibiting disassembly to avoid electric shocks or problems.
	Indicates an item requiring disconnection of the power plug from the electric outlet.
 Memo	Indicates an item intended to provide notes assisting the understanding of the topic in question.
 REF.	Indicates an item of reference assisting the understanding of the topic in question.
	Provides a description of a service mode.
	Provides a description of the nature of an error indication.

The following rules apply throughout this Service Manual:

1. Each chapter contains sections explaining the purpose of specific functions and the relationship between electrical and mechanical systems with reference to the timing of operation.

In the diagrams,  represents the path of mechanical drive; where a signal name accompanies the symbol, the arrow  indicates the direction of the electric signal.

The expression "turn on the power" means flipping on the power switch, closing the front door, and closing the delivery unit door, which results in supplying the machine with power.

2. In the digital circuits, '1' is used to indicate that the voltage level of a given signal is "High", while '0' is used to indicate "Low". (The voltage value, however, differs from circuit to circuit.) In addition, the asterisk (*) as in "DRMD*" indicates that the DRMD signal goes on when '0'.

In practically all cases, the internal mechanisms of a microprocessor cannot be checked in the field. Therefore, the operations of the microprocessors used in the machines are not discussed: they are explained in terms of from sensors to the input of the DC controller PCB and from the output of the DC controller PCB to the loads.

The descriptions in this Service Manual are subject to change without notice for product improvement or other purposes, and major changes will be communicated in the form of Service Information bulletins.

All service persons are expected to have a good understanding of the contents of this Service Manual and all relevant Service Information bulletins and be able to identify and isolate faults in the machine."

Contents

Chapter 1 Specifications

1.1 Product Specifications	1- 1
1.1.1 Specifications	1- 1
1.2 Names of Parts	1- 1
1.2.1 External View	1- 1

Chapter 2 Functions

2.1 Basic Construction	2- 1
2.1.1 Functional Construction	2- 1

Chapter 3 Parts Replacement Procedure

3.1 Removing from the Host Machine	3- 1
3.1.1 Finisher Assembly	3- 1
3.1.1.1 Removing the Rear Cover	3- 1
3.1.1.2 Removing the Lower-right Cover	3- 1
3.1.1.3 Removing the Upper-right Cover	3- 1
3.1.1.4 Removing the shift tray	3- 1
3.1.1.5 Removing the Finisher	3- 1
3.2 External Covers	3- 2
3.2.1 Tray Guide Top Cover	3- 2
3.2.1.1 Removing the Rear Cover of the Tray	3- 2
3.3 Document Feeding System	3- 2
3.3.1 Stack Tray Assembly	3- 2
3.3.1.1 Removing the Stack Tray Assembly Harness	3- 2
3.3.1.2 Removing the Rear Cover of the Tray	3- 2
3.3.1.3 Removing the Stack Tray Assembly	3- 2
3.4 Electrical System	3- 2
3.4.1 Stack Tray Paper Surface Sensor	3- 2
3.4.1.1 Removing the Stack Tray Assembly Harness	3- 2
3.4.1.2 Removing the Rear Cover of the Tray	3- 3
3.4.1.3 Removing the Stack Tray Assembly	3- 3
3.4.1.4 Removing the Bottom Cover of the Optional Tray	3- 3
3.4.1.5 Removing the Stack Tray Paper Surface Detection Sensor	3- 3
3.4.2 Stack Tray Upper Limit Sensor	3- 3
3.4.2.1 Removing the Stack Tray Assmby Harnes	3- 3
3.4.2.2 Removing the Tray Guide Top Cover	3- 3
3.4.2.3 Removing the Stack Tray Assmby	3- 4
3.4.2.4 Removing the Stack Tray Upper Limit Sensor	3- 4
3.4.3 Static Charge Eliminator 1	3- 4
3.4.3.1 Removing the Stack Tray Assembly Harness	3- 4
3.4.3.2 Removing the Tray Guide Top Cover	3- 4

3.4.3.3 Removing the Stack Tray Assmbly	3- 4
3.4.3.4 Removing the Bottom Cover of the Optional Tray	3- 4
3.4.3.5 Removing the Lower-left Cover of the Optional Tray	3- 5
3.4.3.6 Removing the Top Cover of the Optional Tray	3- 5
3.4.3.7 Removing the Electrostatic Discharge Needle	3- 5
3.4.4 Tray Clock Sensor	3- 5
3.4.4.1 Removing the Stack Tray Assmbly Harness	3- 5
3.4.4.2 Removing the Tray Guide Top Cover	3- 5
3.4.4.3 Removing the Stack Tray Assmbly	3- 5
3.4.4.4 Removing the Clock Sensor	3- 6
3.4.5 Optional tray driver PCB	3- 6
3.4.5.1 Removing the Stack Tray Assmbly Harness	3- 6
3.4.5.2 Removing the Tray Guide Top Cover	3- 6
3.4.5.3 Removing the Stack Tray Assembly	3- 6
3.4.5.4 Removing the Bottom Cover of the Optional Tray	3- 6
3.4.5.5 Removing the Optional Tray Drive PCB	3- 6

Chapter 4 Maintenance

4.1 Maintenance and Inspection	4- 1
4.1.1 Periodically Replaced Parts	4- 1
4.1.1.1 Periodically Replaced Parts	4- 1
4.1.2 Durables	4- 1
4.1.2.1 Durables	4- 1
4.1.3 Periodical Servicing	4- 1
4.1.3.1 Periodical Servicing	4- 1
4.2 Variable Resistors (VR), Light-Emitting Diodes (LED), and Check Pins by PCB	4- 1
4.2.1 Functions of the DIP Switch	4- 1

Chapter 5 Error Code

5.1 Service Error Code	5- 1
5.1.1 Service Error Code	5- 1
5.2 Alam Code	5- 1
5.2.1 Alarm Code List	5- 1

Chapter 1 Specifications

Contents

1.1 Product Specifications	1-1
1.1.1 Specifications	1-1
1.2 Names of Parts	1-1
1.2.1 External View	1-1

1.1 Product Specifications

1.1.1 Specifications

T-1-1

Item		Description	Remarks
Stacking method		face-down	
Stack size	feed direction	139.7 to 457 mm	
	cross-feed direction	98.4 to 320 mm	
Number of sheets in a stack	upper tray	small-size:26 mm or less in height large-size:13 mm or less in height	
	lower tray	small-size:26 mm or less in height large-size:13 mm or less in height	80 g/m2 paper

1.2 Names of Parts

1.2.1 External View

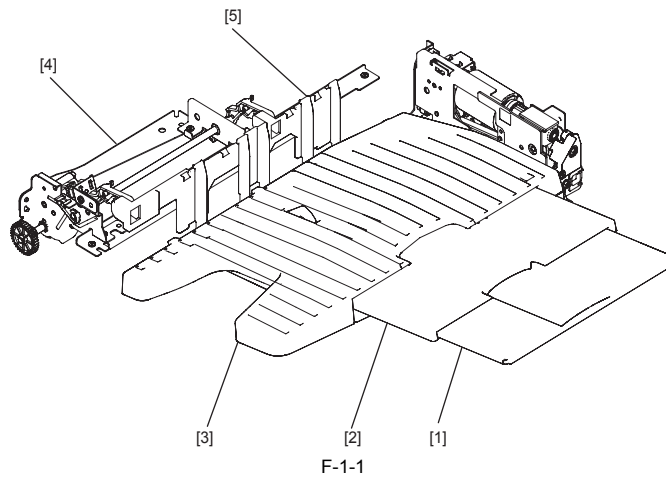

- [1] Stack extension tray 2
- [2] Stack extension tray 1
- [3] Stack tray
- [4] Drive unit
- [5] Shutter

Chapter 2 Functions

Contents

2.1 Basic Construction	2-1
2.1.1 Functional Construction	2-1

2.1 Basic Construction

2.1.1 Functional Construction

The finisher additional tray is an option, and is designed as an addition (No. 2 tray) to the finisher's standard tray. It is equipped with an option tray paper sensor (PI12) to detect the presence/absence of paper on it.

Chapter 3 Parts Replacement Procedure

Contents

3.1 Removing from the Host Machine	3-1
3.1.1 Finisher Assembly	3-1
3.1.1.1 Removing the Rear Cover	3-1
3.1.1.2 Removing the Lower-right Cover	3-1
3.1.1.3 Removing the Upper-right Cover	3-1
3.1.1.4 Removing the shift tray	3-1
3.1.1.5 Removing the Finisher	3-1
3.2 External Covers	3-2
3.2.1 Tray Guide Top Cover	3-2
3.2.1.1 Removing the Rear Cover of the Tray	3-2
3.3 Document Feeding System.....	3-2
3.3.1 Stack Tray Assembly.....	3-2
3.3.1.1 Removing the Stack Tray Assembly Harness	3-2
3.3.1.2 Removing the Rear Cover of the Tray	3-2
3.3.1.3 Removing the Stack Tray Assembly	3-2
3.4 Electrical System	3-2
3.4.1 Stack Tray Paper Surface Sensor	3-2
3.4.1.1 Removing the Stack Tray Assembly Harness	3-2
3.4.1.2 Removing the Rear Cover of the Tray	3-3
3.4.1.3 Removing the Stack Tray Assembly	3-3
3.4.1.4 Removing the Bottom Cover of the Optional Tray	3-3
3.4.1.5 Removing the Stack Tray Paper Surface Detection Sensor	3-3
3.4.2 Stack Tray Upper Limit Sensor.....	3-3
3.4.2.1 Removing the Stack Tray Assmby Harnes.....	3-3
3.4.2.2 Removing the Tray Guide Top Cover	3-3
3.4.2.3 Removing the Stack Tray Assmby.....	3-4
3.4.2.4 Removing the Stack Tray Upper Limit Sensor	3-4
3.4.3 Static Charge Eliminator 1	3-4
3.4.3.1 Removing the Stack Tray Assembly Harness	3-4
3.4.3.2 Removing the Tray Guide Top Cover	3-4
3.4.3.3 Removing the Stack Tray Assmby.....	3-4
3.4.3.4 Removing the Bottom Cover of the Optional Tray	3-4
3.4.3.5 Removing the Lower-left Cover of the Optional Tray.....	3-5
3.4.3.6 Removing the Top Cover of the Optional Tray.....	3-5
3.4.3.7 Removing the Electrostatic Discharge Needle	3-5
3.4.4 Tray Clock Sensor	3-5
3.4.4.1 Removing the Stack Tray Assmby Harness	3-5
3.4.4.2 Removing the Tray Guide Top Cover	3-5
3.4.4.3 Removing the Stack Tray Assmby.....	3-5
3.4.4.4 Removing the Clock Sensor	3-6
3.4.5 Optional tray driver PCB.....	3-6
3.4.5.1 Removing the Stack Tray Assmby Harness	3-6
3.4.5.2 Removing the Tray Guide Top Cover	3-6
3.4.5.3 Removing the Stack Tray Assembly	3-6

3.4.5.4 Removing the Bottom Cover of the Optional Tray	3-6
3.4.5.5 Removing the Optional Tray Drive PCB.....	3-6

3.1 Removing from the Host Machine

3.1.1 Finisher Assembly

3.1.1.1 Removing the Rear Cover

- 1) Open the front cover [1].
- 2) Remove the four RS tightening screws (M3 x 8) [1], and then detach the rear cover [2].

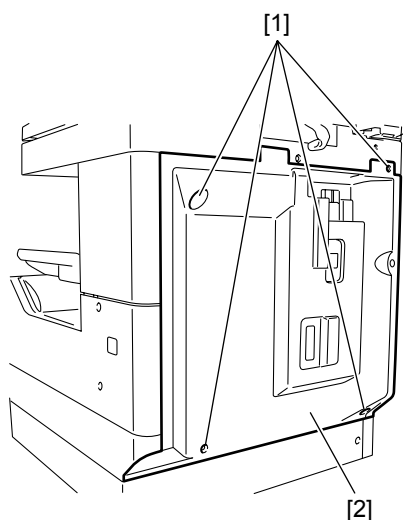

F-3-1

3.1.1.2 Removing the Lower-right Cover

- 1) Remove the five RS tightening screws (M3 x 8) [1]. Release the two hooks [2], and then detach the lower-right cover [3].

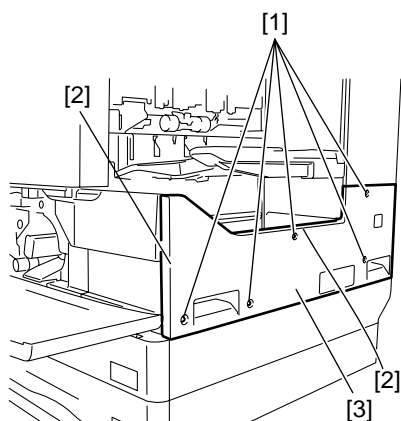

F-3-2

3.1.1.3 Removing the Upper-right Cover

- 1) Remove the RS tightening screw (M3 x 8) [1], and then detach the upper-right cover [2].

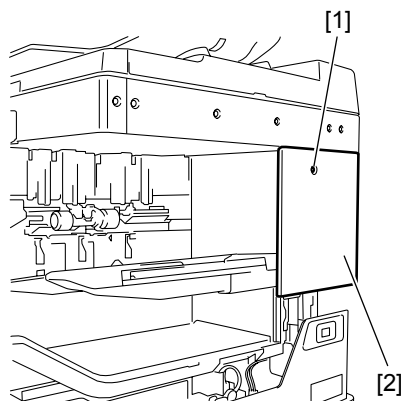

F-3-3

3.1.1.4 Removing the shift tray

- 1) Disconnect the connectors (J905) [1] and (J906) [2] on the finisher controller PCB, and then remove the two binding screws with toothed washer (M3 x 6) [3].

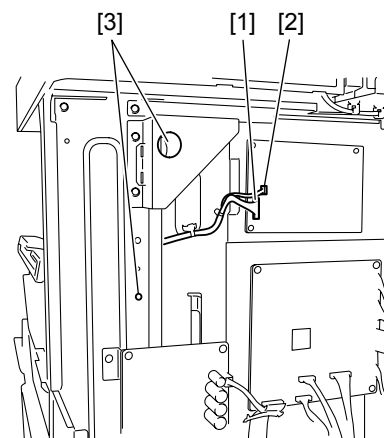

F-3-4

- 2) Remove the three TP binding screws (M3 x 6) [4], and then remove the shift tray [5] forward.

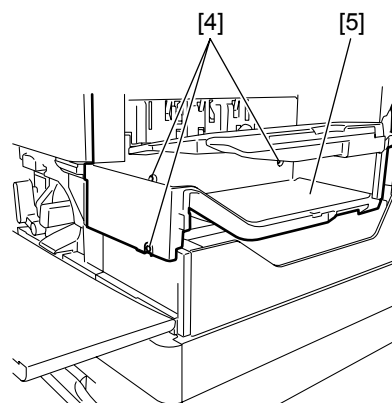

F-3-5



When removing the tray unit, be careful not to get your hands hit or pinched. Do not hold the tray.

3.1.1.5 Removing the Finisher

- 1) Disconnect the connector (J203) [1] on the DC controller PCB and the connector (J50) [2] on the optional power supply PCB, and then disconnect the harness from the guide.

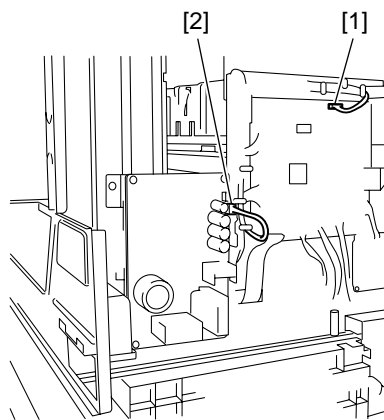

F-3-6

- 2) Remove the three TP binding screws (M3 x 6) [3], and then remove the finisher [4] forward.

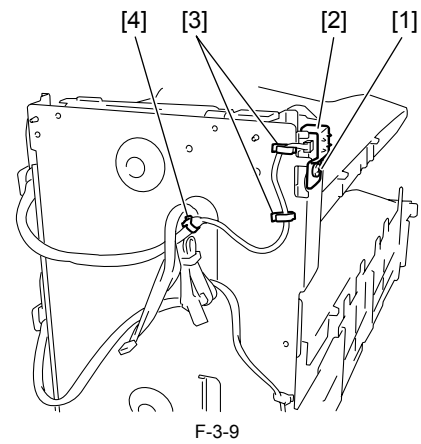
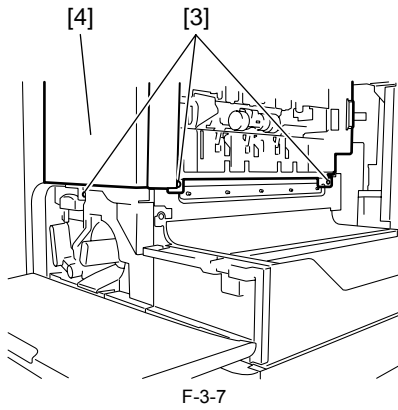

When removing the tray unit, be careful not to get your hands hit or pinched. Do not hold the tray.

3.2 External Covers

3.2.1 Tray Guide Top Cover

3.2.1.1 Removing the Rear Cover of the Tray

1) Remove the two RS tightening screws (M3 x 8) [1], and then detach the rear cover [2] of the tray.

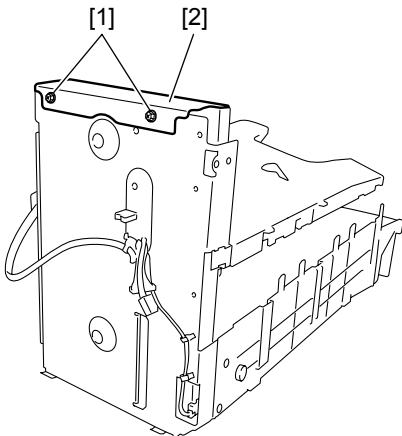

F-3-8

3.3 Document Feeding System

3.3.1 Stack Tray Assembly

3.3.1.1 Removing the Stack Tray Assembly Harness

1) Remove the screw [1], and then remove the sensor mounting plate [2].
2) Remove the harness from the two wire saddles [3], and then remove the reusable band [4].

3.3.1.2 Removing the Rear Cover of the Tray

1) Remove the two RS tightening screws (M3 x 8) [1], and then detach the rear cover [2] of the tray.

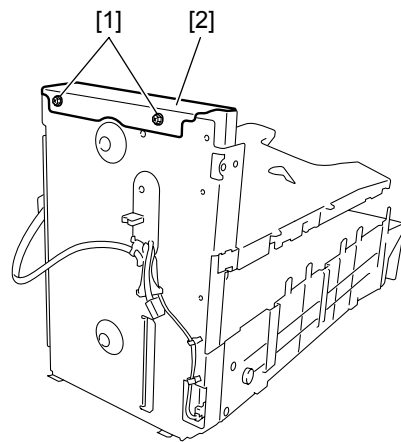

F-3-10

3.3.1.3 Removing the Stack Tray Assembly

1) Holding the stack tray [1], remove it in the direction of the arrow.

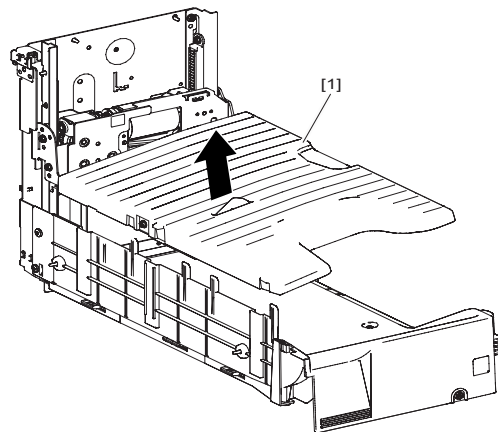

F-3-11

3.4 Electrical System

3.4.1 Stack Tray Paper Surface Sensor

3.4.1.1 Removing the Stack Tray Assembly Harness

1) Remove the screw [1], and then remove the sensor mounting plate [2].
2) Remove the harness from the two wire saddles [3], and then remove the reusable band [4].

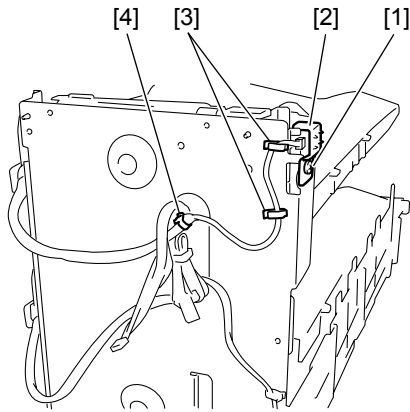

F-3-12

3.4.1.2 Removing the Rear Cover of the Tray

1) Remove the two RS tightening screws (M3 x 8) [1], and then detach the rear cover [2] of the tray.

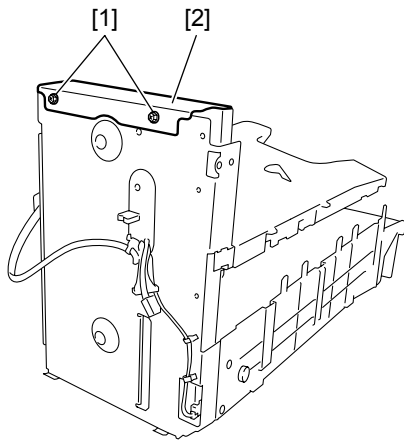

F-3-13

3.4.1.3 Removing the Stack Tray Assembly

1) Holding the stack tray [1], remove it in the direction of the arrow.

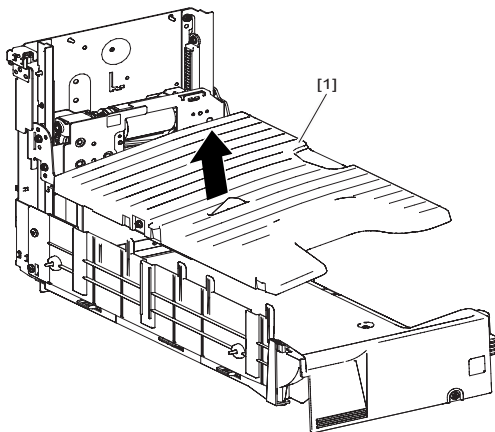

F-3-14

3.4.1.4 Removing the Bottom Cover of the Optional Tray

1) Remove the two P tightening screws (M4 x 12) [1], and then remove the bottom cover [2] of the optional tray.

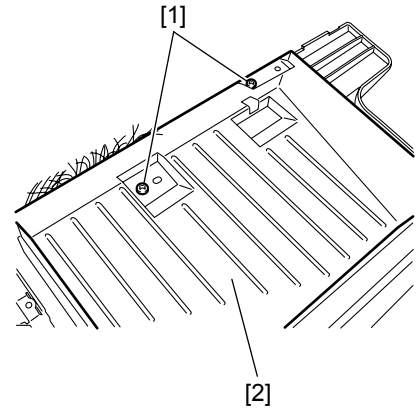

F-3-15

3.4.1.5 Removing the Stack Tray Paper Surface Detection Sensor

1) Disconnect the connector [1], and then remove the stack tray paper surface detection sensor [2].

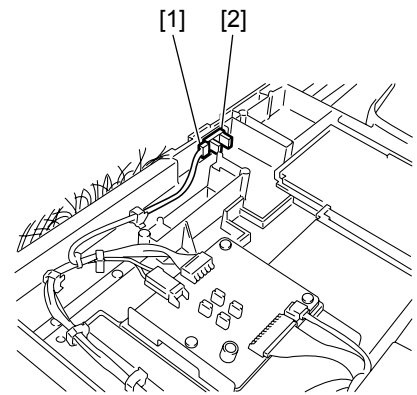

F-3-16

3.4.2 Stack Tray Upper Limit Sensor

3.4.2.1 Removing the Stack Tray Assembly Harness

1) Remove the screw [1], and then remove the sensor mounting plate [2].
2) Remove the harness from the two wire saddles [3], and then remove the reusable band [4].

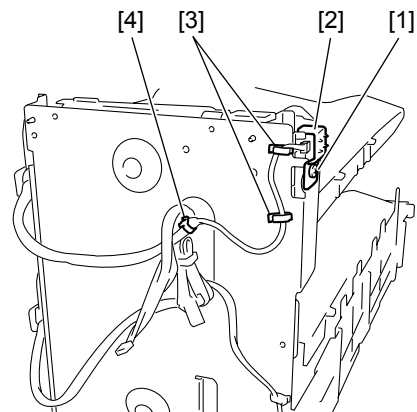

F-3-17

3.4.2.2 Removing the Tray Guide Top Cover

1) Remove the two RS tightening screws (M3 x 8) [1], and then detach the tray guide top cover [2].

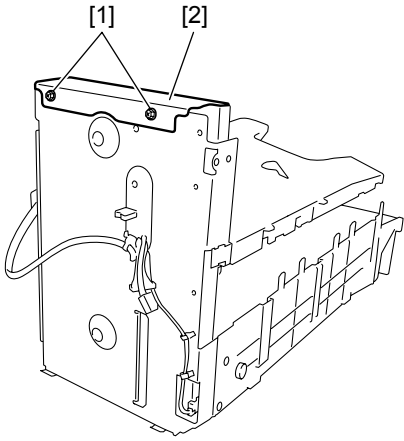

F-3-18

3.4.2.3 Removing the Stack Tray Assembly

1) Holding the stack tray [1], remove it in the direction of the arrow.

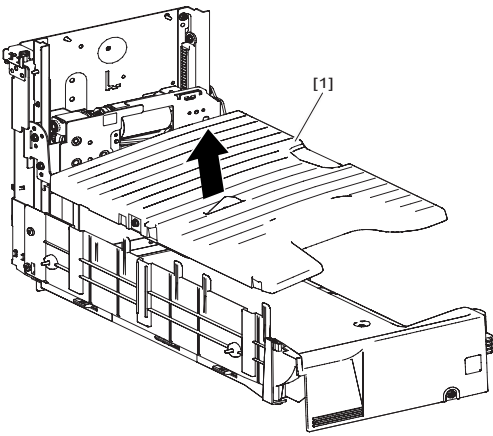

F-3-19

3.4.2.4 Removing the Stack Tray Upper Limit Sensor

1) Disconnect the connector [1], and then remove the stack tray upper limit sensor [2].

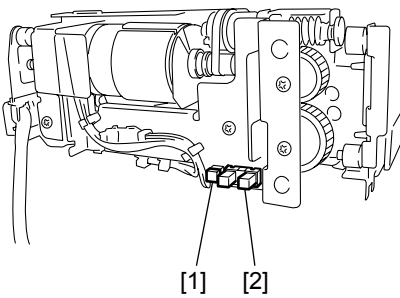

F-3-20

3.4.3 Static Charge Eliminator 1

3.4.3.1 Removing the Stack Tray Assembly Harness

1) Remove the screw [1], and then remove the sensor mounting plate [2].
 2) Remove the harness from the two wire saddles [3], and then remove the reusable band [4].

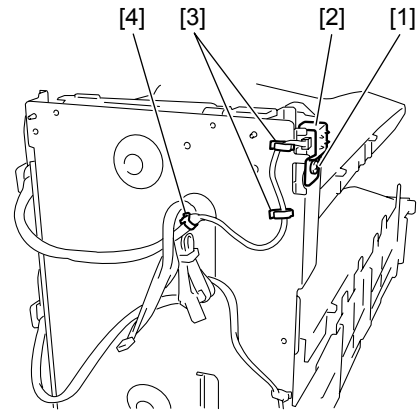

F-3-21

3.4.3.2 Removing the Tray Guide Top Cover

1) Remove the two RS tightening screws (M3 x 8) [1], and then detach the rear cover [2] of the tray.

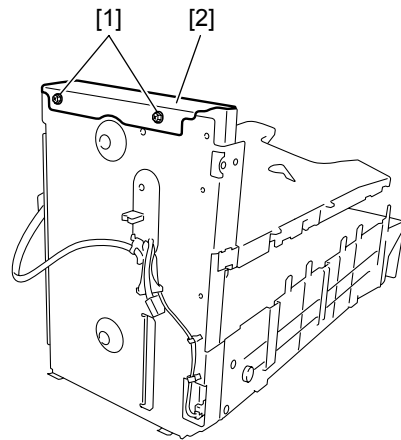

F-3-22

3.4.3.3 Removing the Stack Tray Assembly

1) Holding the stack tray [1], remove it in the direction of the arrow.

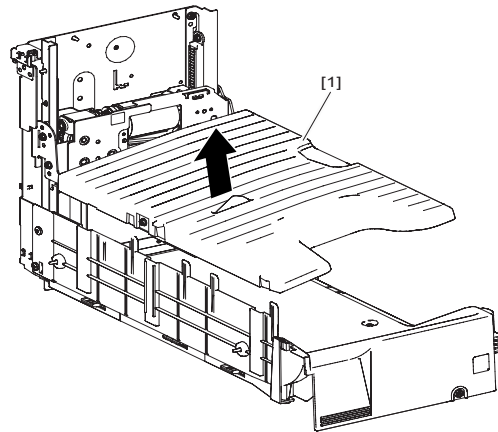

F-3-23

3.4.3.4 Removing the Bottom Cover of the Optional Tray

1) Remove the two P tightening screws (M4 x 12) [1], and then remove the bottom cover [2] of the optional tray.

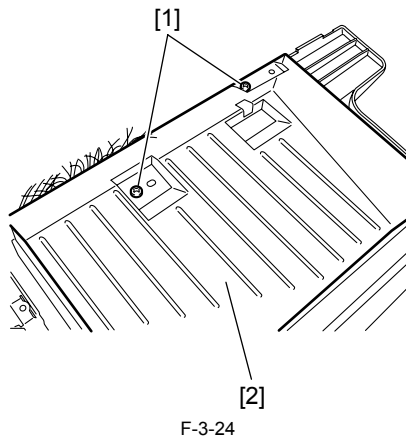

F-3-24

3.4.3.5 Removing the Lower-left Cover of the Optional Tray

1) Remove the two RS tightening screws (M3 x 8) [1], and then remove the lower-left cover of the optional tray [2].

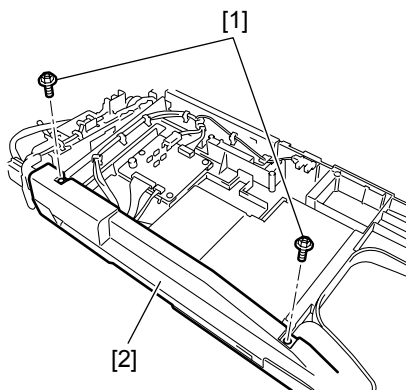

F-3-25

3.4.3.6 Removing the Top Cover of the Optional Tray

1) Remove the two P tightening screws (M4 x 12) [1], and then remove the RS tightening screw (M3 x 8) [2]. Disconnect the connector [3], and then detach the top cover [4] of the optional tray.

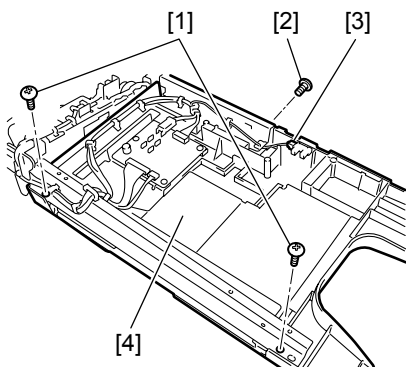

F-3-26

3.4.3.7 Removing the Electrostatic Discharge Needle

1) Remove the binding screw (M3 x 4) [1], and then remove the electrostatic discharge needle [2] by sliding it in the direction of the arrow.

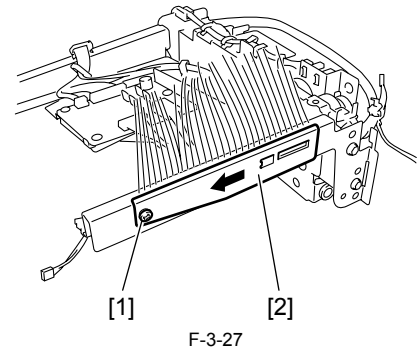

F-3-27

3.4.4 Tray Clock Sensor

3.4.4.1 Removing the Stack Tray Assembly Harness

1) Remove the screw [1], and then remove the sensor mounting plate [2].
2) Remove the harness from the two wire saddles [3], and then remove the reusable band [4].

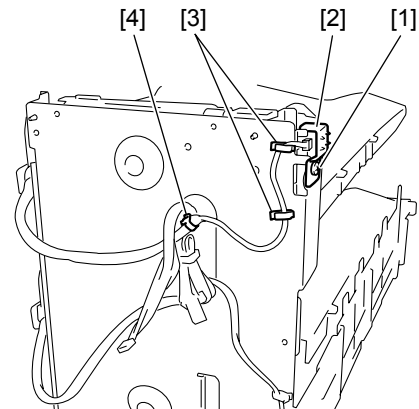

F-3-28

3.4.4.2 Removing the Tray Guide Top Cover

1) Remove the two RS tightening screws (M3 x 8) [1], and then detach the rear cover [2] of the tray.

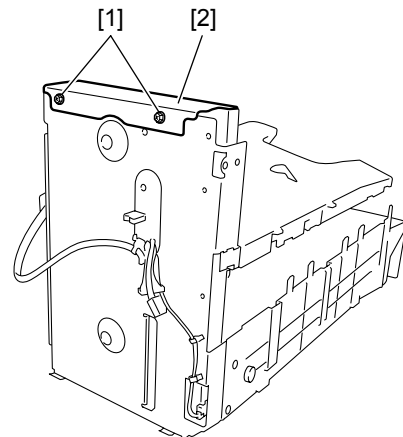

F-3-29

3.4.4.3 Removing the Stack Tray Assembly

1) Holding the stack tray [1], remove it in the direction of the arrow.

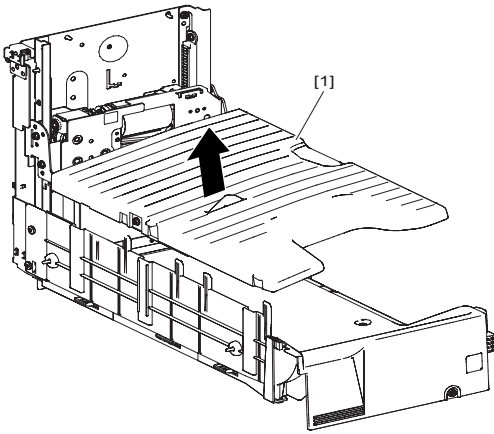

F-3-30

3.4.4.4 Removing the Clock Sensor

- 1) Remove the harness from the four wire saddles [1] and three mini-clamps [2], and then remove the four binding screws (M3 x 4) [3].
- 2) Disconnect the connector [4], and then remove the tray clock sensor [5].

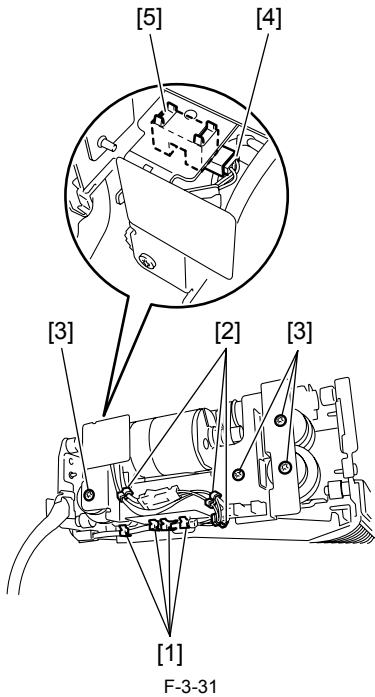

F-3-31

3.4.5 Optional tray driver PCB

3.4.5.1 Removing the Stack Tray Assmly Harness

- 1) Remove the screw [1], and then remove the sensor mounting plate [2].
- 2) Remove the harness from the two wire saddles [3], and then remove the reusable band [4].

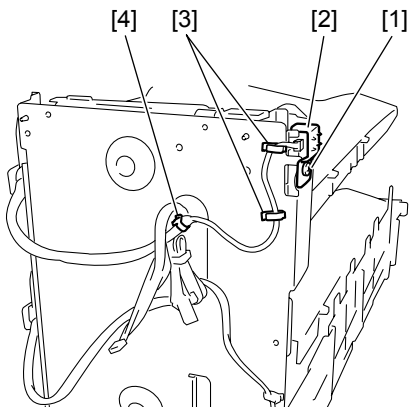

F-3-32

3.4.5.2 Removing the Tray Guide Top Cover

- 1) Remove the two RS tightening screws (M3 x 8) [1], and then detach the rear cover [2] of the tray.

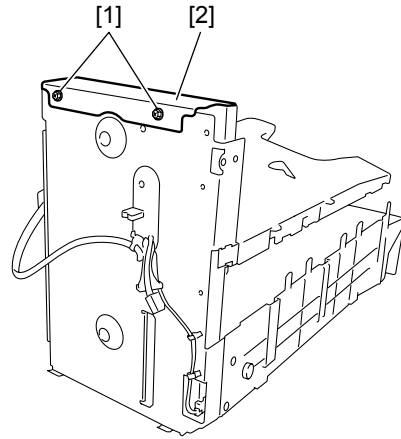

F-3-33

3.4.5.3 Removing the Stack Tray Assembly

- 1) Holding the stack tray [1], remove it in the direction of the arrow.

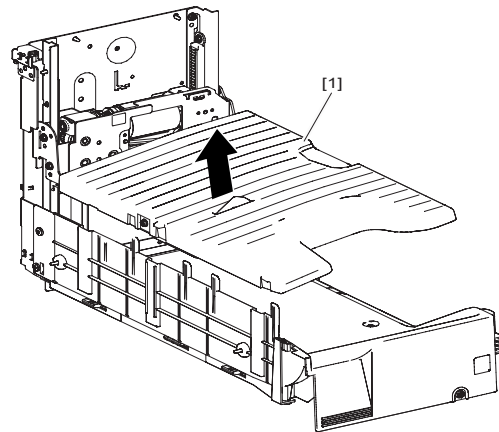

F-3-34

3.4.5.4 Removing the Bottom Cover of the Optional Tray

- 1) Remove the two P tightening screws (M4 x 12) [1], and then remove the bottom cover [2] of the optional tray.

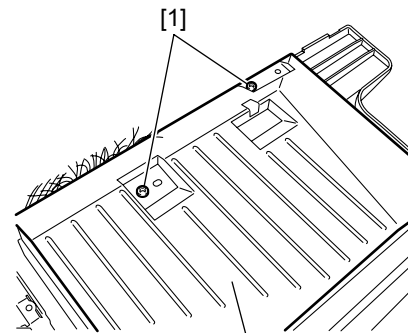

F-3-35

3.4.5.5 Removing the Optional Tray Drive PCB

- 1) Disconnect the four connectors [1], remove the three binding screws (M3 x 4) [2], and then remove the optional tray driver PCB [3].

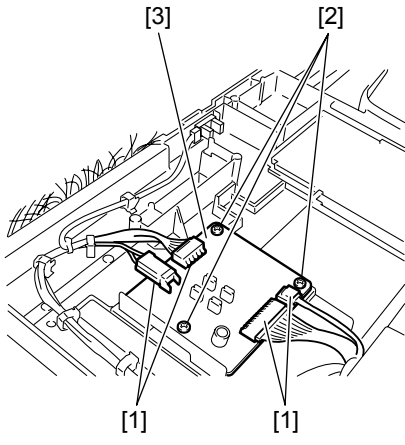

F-3-36

Chapter 4 Maintenance

Contents

4.1 Maintenance and Inspection	4-1
4.1.1 Periodically Replaced Parts	4-1
4.1.1.1 Periodically Replaced Parts	4-1
4.1.2 Durables	4-1
4.1.2.1 Durables	4-1
4.1.3 Periodical Servicing	4-1
4.1.3.1 Periodical Servicing	4-1
4.2 Variable Resistors (VR), Light-Emitting Diodes (LED), and Check Pins by PCB	4-1
4.2.1 Functions of the DIP Switch	4-1

4.1 Maintenance and Inspection

4.1.1 Periodically Replaced Parts

4.1.1.1 Periodically Replaced Parts

The machine does not have parts that must be replaced on a periodical basis.

4.1.2 Durables

4.1.2.1 Durables

This machine does not have items that may be classified as durables.

4.1.3 Periodical Servicing

4.1.3.1 Periodical Servicing

The machine does not have items that must be serviced on a periodical basis.

4.2 Variable Resistors (VR), Light-Emitting Diodes (LED), and Check Pins by PCB

4.2.1 Functions of the DIP Switch

The DIP switch (SW1) on the finisher controller PCB possesses the following functions:

-Press it to switch over operation.

-Shift all bits of SW1 at the end of a check.

1. Checking the Operation of the Stack Unit

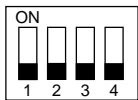

F-4-1

Operations

<With the Option Tray at the Position of Paper Surface Detection>

1. The option tray moves down 20 mm (until it turns off the paper surface sensor).
2. The option tray moves up and stops when it turns off the paper surface detection sensor.

<With the Option Tray Not at the Position of Paper Surface Detection>

1. The machine executes a series of operations used to move the option tray to the position of paper surface detection.

<Moving the Stack Tray for Packing>

-Use it to move the tray so that it will be located suitably for packing.

Chapter 5 Error Code

Contents

5.1 Service Error Code	5-1
5.1.1 Service Error Code	5-1
5.2 Alarm Code.....	5-1
5.2.1 Alarm Code List	5-1

5.1 Service Error Code

5.1.1 Service Error Code

T-5-1

Code	Detail code	Description	Timing of detection
E542	0001	-The option stack tray motor or the finisher controller PCB is faulty.	-The optional stack tray has been driven, but the paper surface is not detected.
	0002	-The option stack tray home position sensor is faulty.	-The shift does not end within a specific period of time (i.e., to the point of paper retrieval).
	0003	-The option stack tray clock sensor is faulty.	-The operation stack tray has been driven for ascent, but it does not reach home position within 3000 msec.
	0004	-The optional stack tray motor is subjected to an abnormal load.	-The option stack tray has been driven for descent, but it does not move past home position within 3000 msec.
	0005		-The option stack tray has been driven, but the encoder clock signal of the tray is not detected twice or more within 300 msec.
E584	0001	-The shutter drive motor or the finisher controller PCB is faulty.* -The shutter open sensor is faulty. -The shutter clutch is faulty	-When the shutter unit is being opened, the shutter open sensor does not go on within 1000 msec, not ending the operation.
	0002	-The shutter drive motor is subjected to an abnormal load at time of shutter operation.*	-When the shutter unit is being closed, the shutter closed sensor does not go off within 1000 msec, not ending the operation.

*Shutter drive motor, used to operate the shutter by means of a drive clutch.

5.2 Alarm Code

5.2.1 Alarm Code List

T-5-2

Error	Description	Alarm code	Resetting
Stack overflow (w/ option tray installed)	1. When 50 sheets have been delivered since the 150-sheet sensor (option tray lower limit) was turned on with the top surface of the paper loaded in the tray detected by the paper surface sensor 2. In mixed size mode, the paper surface sensor goes on for 150 sheets when checking the stack of sheets placed on the tray (option tray lower limit). 3. The number of sheets on the tray has reached a specific number. 4. The number of sheets on the tray to be stapled has reached a specific number of sets. 5. With paper on the tray at power-on, the condition in 2. above is identified.	02	Remove the paper from the stack tray.

(*1) Stacked papers overload detection sensor (standard and option trays) detects full when stacked as follows:
small size: 200 sheets, large size: 150 sheets, stapled booklet: 30 booklets, mixed mode and size: 150 sheets (If papers are stacked on the tray when the power is turned on, it will be considered as mixed mode and size.)

Sep 14 2005

Canon